

In general, there are **two ways** to attach your equipment to the centre column. The basis is always the connection flange which, if necessary, can be extended with an additional adapter to suit your equipment. The connecting flange and centre column are friction-locked (tapered surfaces).

(1) Connecting flange; (2) Centre column; (3) Pipe spindle; (4) Allen screw
 (5) Thrust ring; (6) Nut M32x1.5; (7) Driver; (8) Threaded ring M40x1.5

Variant A

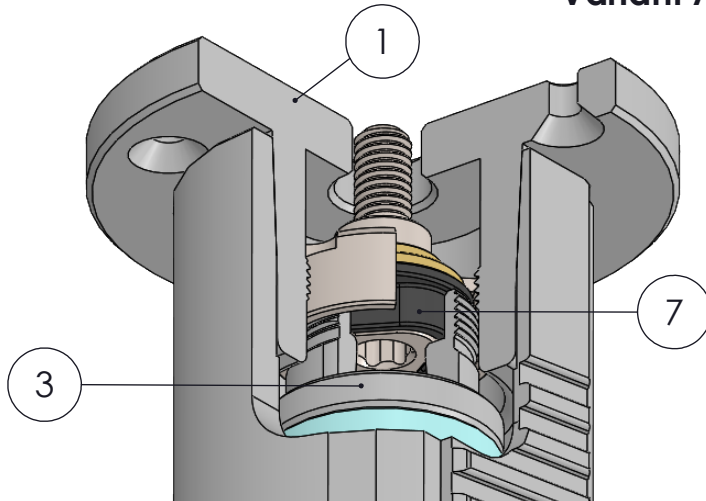

Characteristics:

- The connection flange always remains in the centre column
- Your equipment is held solely by the pipe spindle with Allen screw.
- Quick assembly and disassembly of your equipment, which remains usable for other shots (e.g. tripods)
- The connecting flange can be quickly removed without equipment by means of ejector (see reverse side)
- Ideal for smaller mounts

Important note!
 without threaded ring M40x1.5!

Variant B

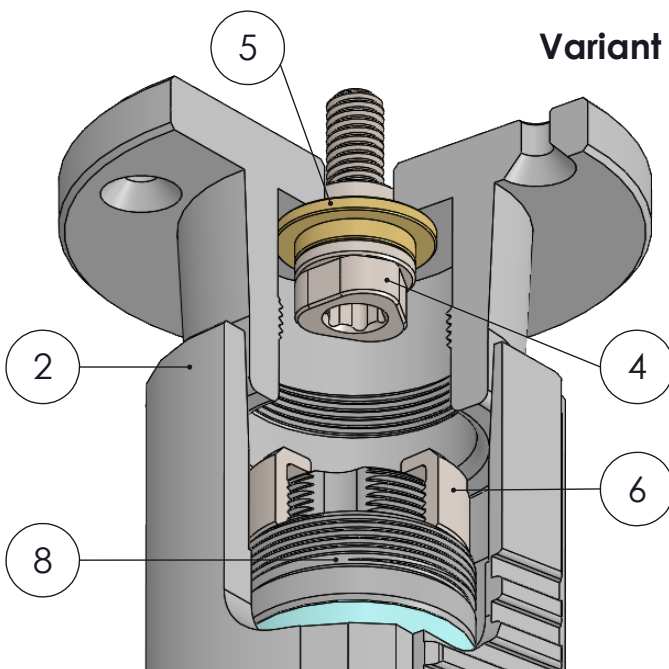

Characteristics:

- The connection flange is constantly on the equipment!
- Quick and safe insertion into the centre column
- The connecting flange is secured via the pipe spindle with threaded ring.
- With frequently changing use of different equipment (e.g. different mounts)
- Removal of the equipment only according to a defined sequence of steps (handling see reverse side)

Important note!
 without driver!

Characteristics:

- The connection flange with adapter washer (can also be combined as a custom-made individual piece) remains in the centre column and is secured via variant A or variant B (but without Allen screw)

Variant C

is a combination of variant A and B

- For medium-sized mounts or similar equipment that is fastened **separately** from above.
- Removal with ejector

Important note: Always clamp the centre column when mounting or removing the equipment! This also applies to the transport. Avoid any sudden movements along the stroke axis! The centre column must not be moved out of the guide rings or removed! Please always ensure that the taper surfaces of the connecting flange and centre column are intact!

General information about the crank drive: The worm gear and pinion are made of wear-resistant plastic. Their axles have ball bearings on both sides. This combination allows for a maintenance-free and low-friction gear/hydraulic/wet brake oil, a short crank arm and an effective gear ratio (1.8 crank revolution per 1 cm stroke or 0.55 cm stroke per crank revolution).

A locking mechanism prevents the centre column from retracting and produces a quiet ticking sound during lifting (every 180° crank revolution)

The crank itself is equipped with an integrated slipping coupling as overload protection (overtravel of the total stroke or too high load >60 kg). Primarily for transport or to protect against accidental operation, it can be removed. Press the central cover cap with your thumb and pull off the crank. When attaching, only the correct position in the axial alignment must be ensured.

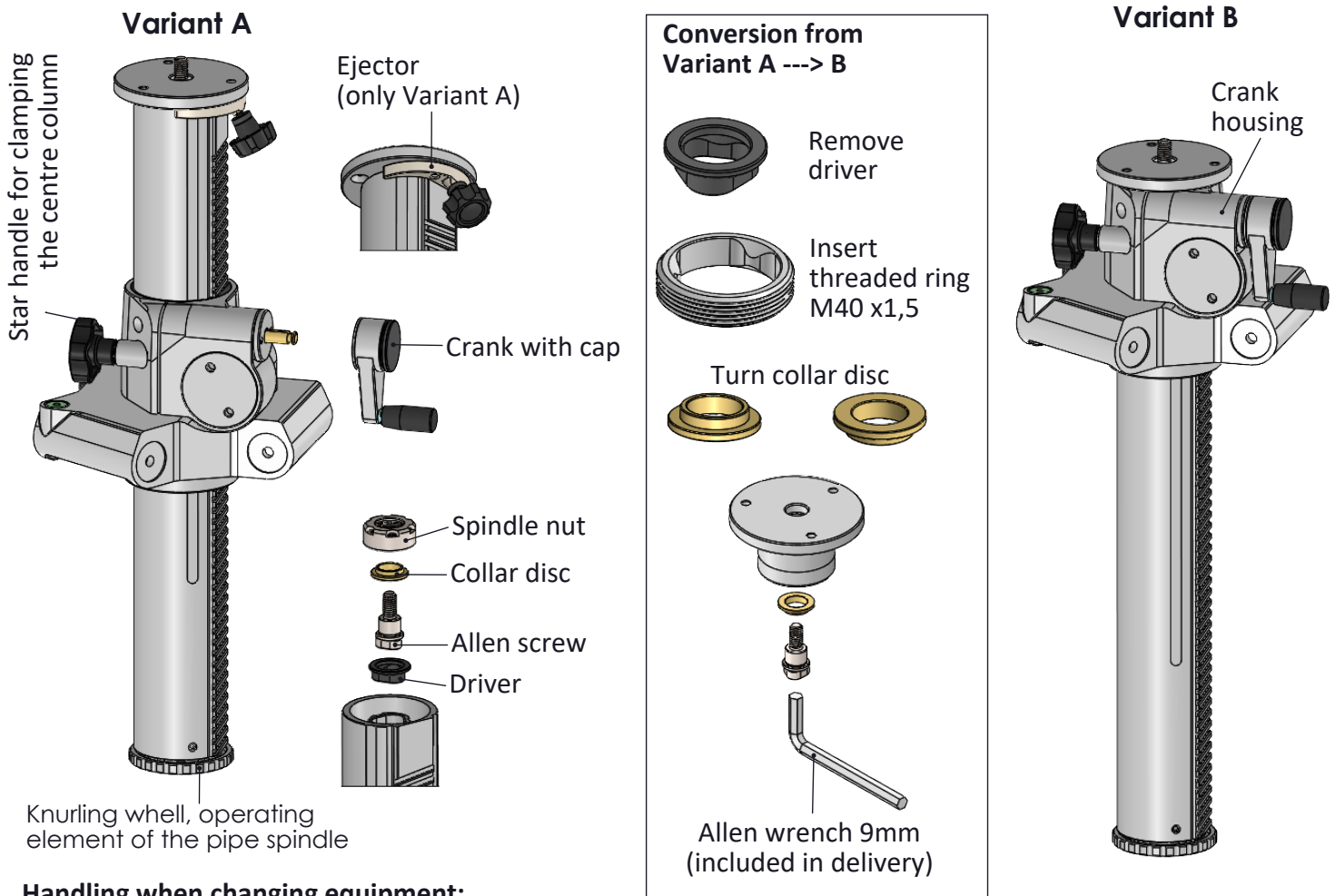

Handling when changing equipment:

Variant A

Due to other connection dimensions, such as thread size or length or/and a different design of the basic shape of your equipment, the connection flange, as well as the Allen screw must be exchanged. First, remove your equipment. Second, using the ejector, push the connecting flange out of the tapered seat of the centre column. Loosen the nut and remove the Allen screw with the thrust ring. After replacing the Allen screw, insert it together with the thrust ring positively into the driver and close everything only hand-tight with the spindle nut. It is recommended to lift the pipe spindle by pressing the knurled wheel. Finally, reinsert the connecting flange into the centre column.

Variant B

Here the connection flange is mounted on the equipment or extended with an adapter disk, which does not have a centre thread. To remove it, first loosen the tube spindle 1-2 turns. Then crank the centre column all the way down until the connecting flange rests on the crankcase and is pushed out of the tapered seat of the centre column. The overload protection of the crank is clearly noticeable. Crank the centre column back up a little (approx. 5 mm) and loosen the tube spindle completely. Only now can the equipment be removed. Insert the new equipment into the centre column and pull it firmly into the tapered seat with the tube spindle.